

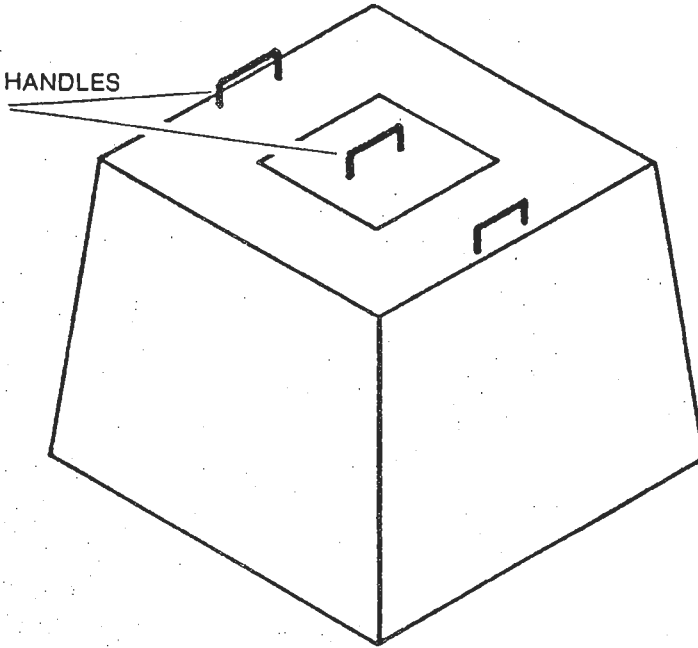

WELL COVER

WELL COVER
ITEM # W7•001
WEIGHT: 3000 LB.

GALVANIZED STEEL LIFT HANDLES



- SPECIFICATIONS:**
- 5000 PSI at 28 days
 - Air entraining: 5-7%
 - 10 mm reinforcing as shown below
 - Thickness of concrete: sides - 2½"
top - 4"

NOTES: • Excellent well protection

10 mm REINFORCING

